

Menge: Maßstab:

Material: Gewicht: Dichte:

	Datum	Name
Gezeichnet	05.04.2022	E. Nadulski
geändert		
geändert		

**FRP 900 pipe SN 5000 / SN 10000
+ cone EN 1917 DIN 4034-1**

www.predl.eu



new manhole in old manhole

a
A4

Pfad:

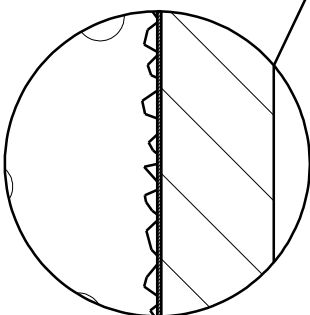
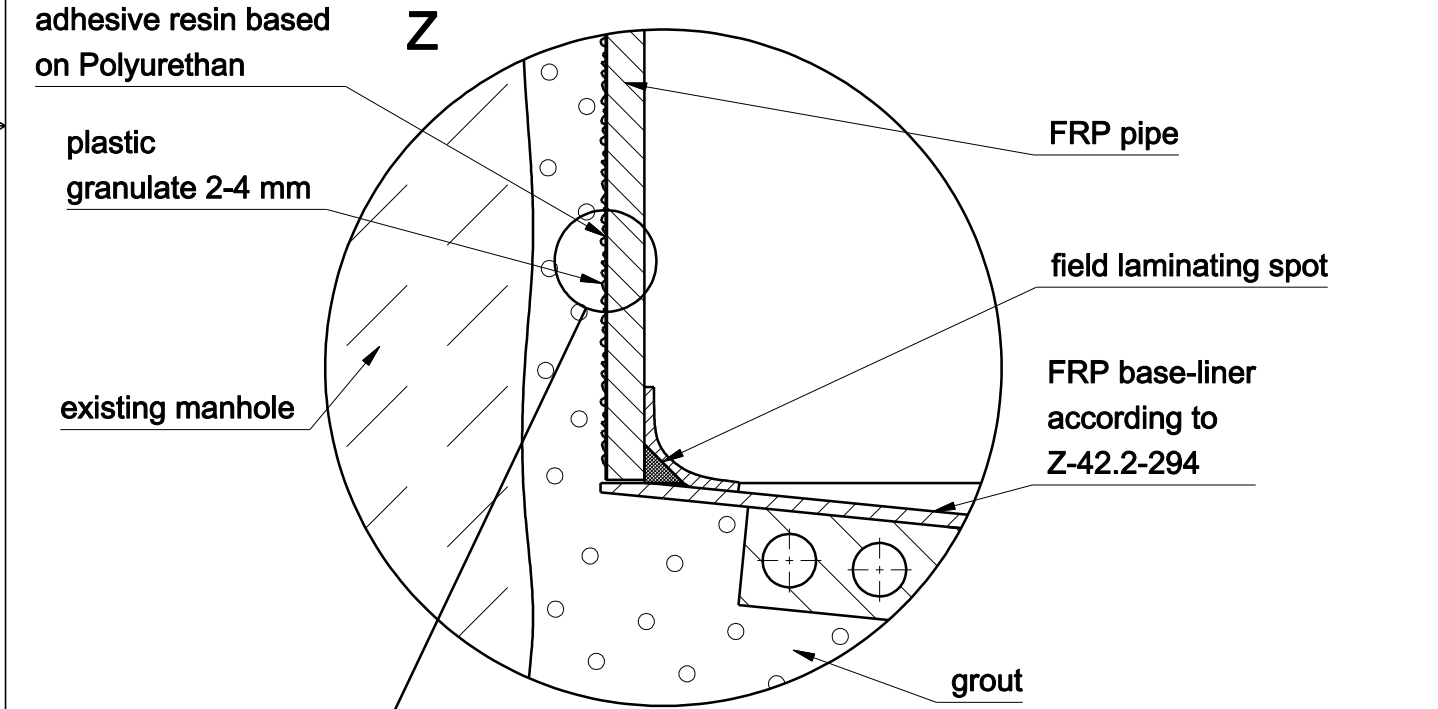
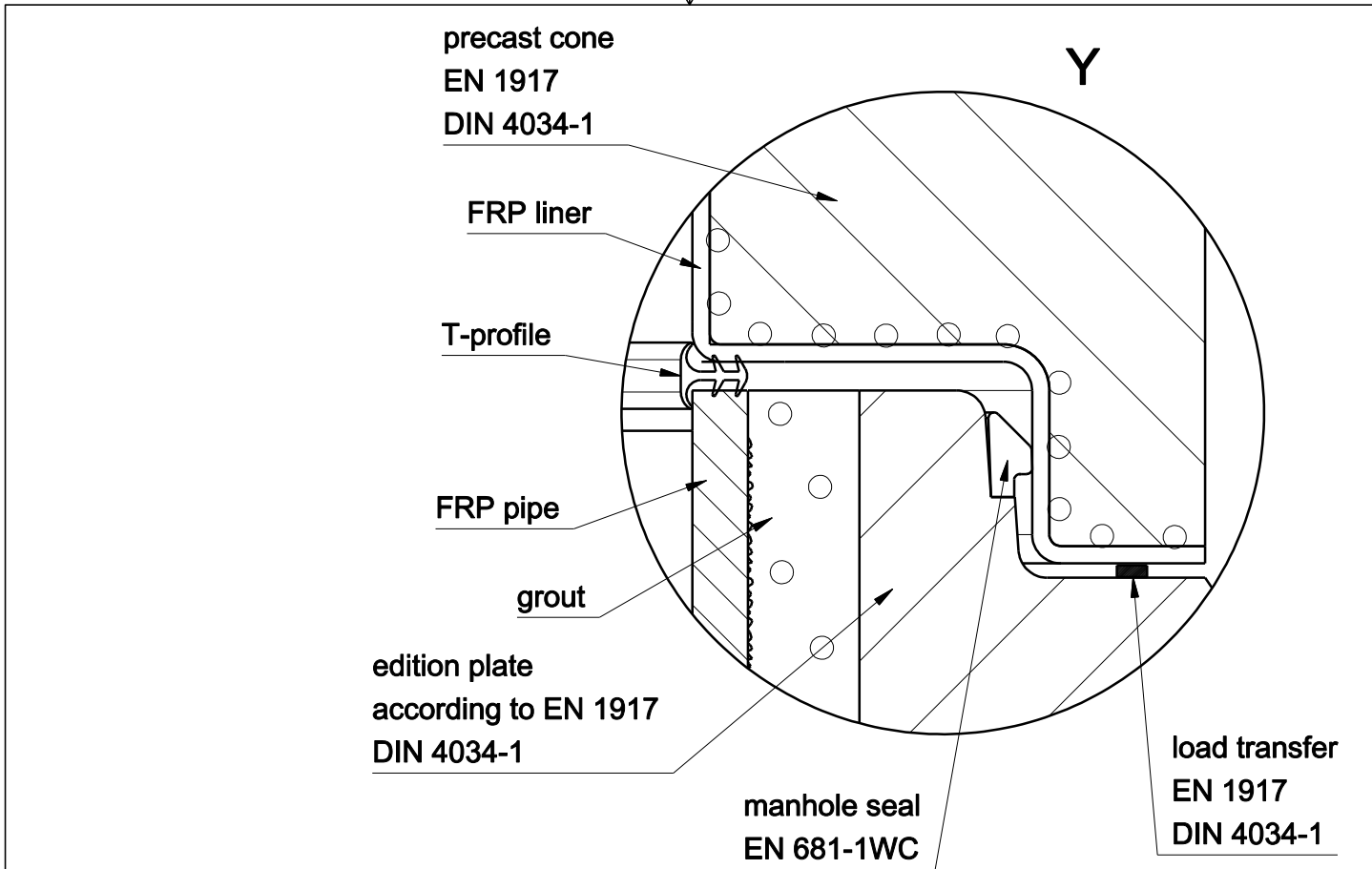

	Menge:		Maßstab:													
	Material:		Gewicht:	Dichte:												
<table border="1"> <tr> <td></td> <td>Datum</td> <td>Name</td> </tr> <tr> <td><small>Gezeichnet</small></td> <td>05.04.2022</td> <td>E. Nadulski</td> </tr> <tr> <td><small>geändert</small></td> <td></td> <td></td> </tr> <tr> <td><small>geändert</small></td> <td></td> <td></td> </tr> </table>		Datum	Name	<small>Gezeichnet</small>	05.04.2022	E. Nadulski	<small>geändert</small>			<small>geändert</small>			FRP 900 pipe SN 5000 / SN 10000 + cone EN 1917 DIN 4034-1			
	Datum	Name														
<small>Gezeichnet</small>	05.04.2022	E. Nadulski														
<small>geändert</small>																
<small>geändert</small>																
new manhole in old manhole				a A4												
www.predl.eu <small>Schutzvermerk nach DIN34 beachten</small> Pfad:																

dismantling height

approx. 500

Ø 625

flat top
EN 1917
DIN 4034-1
with FRP

Y

Ø 1000

FRP DN 900 / SN 5000
rehabilitation pipe

grout

existing manhole

Z

stainless steel
clamping sleeve

FRP Base-liner

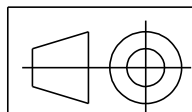

Menge:

Maßstab:

Material:

Gewicht:

Dichte:

Datum

Name

Gezeichnet 05.04.2022 E. Nadulski

geändert

geändert

www.predl.eu

PREDL®

Schutzvermerk nach DIN34 beachten

Pfad:

**FRP 900 / SN 5000
+ flat top DIN 4034-1**

new manhole in old manhole

b

A4

flat top
EN 1917
DIN 4034-1
with FRP

Y 6:1

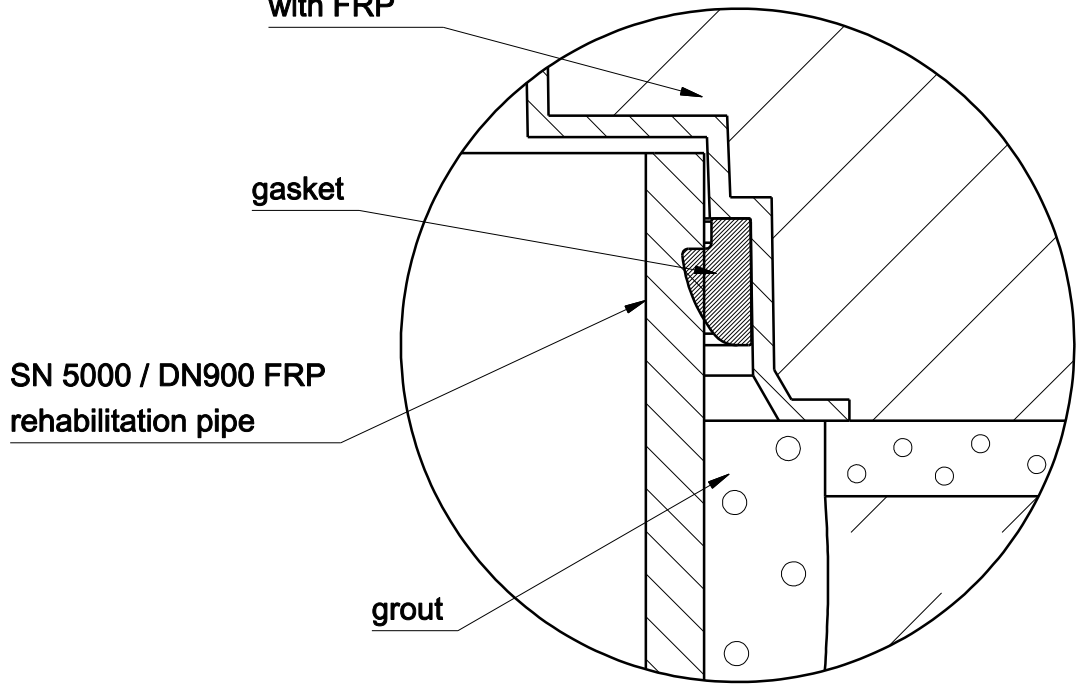

adhesive resin based
on Polyurethan

Z

plastic anchor
granulate 2-4 mm

FRP pipe
SN 5000 / DN 900

existing manhole

field laminating spot

FRP base-liner

anchor

grout

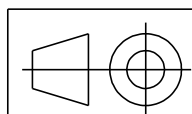
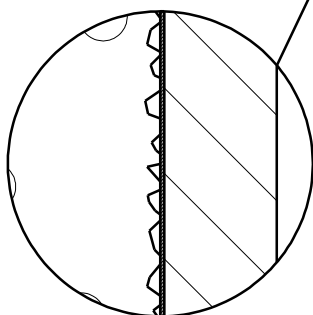
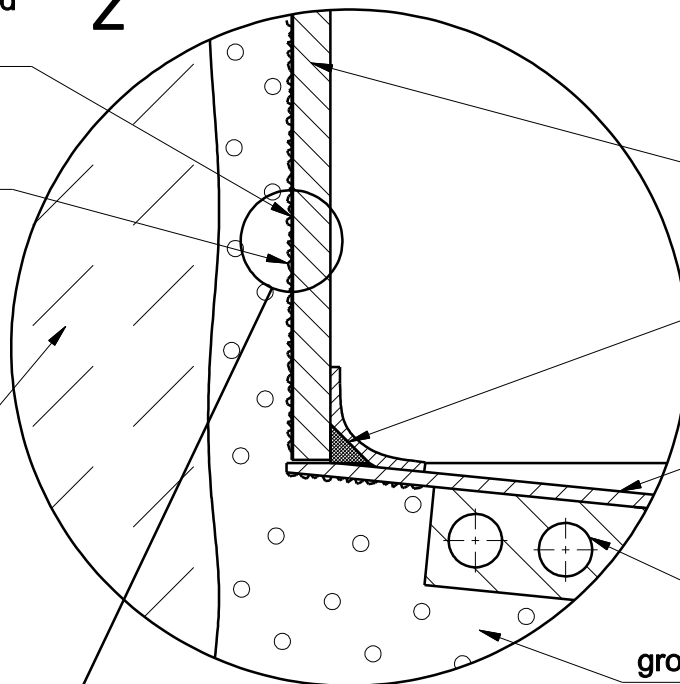

Menge:

Maßstab:

Material:

Gewicht:

Dichte:

	Datum	Name
Gezeichnet	05.04.2022	E. Nadulski
geändert		
geändert		

**FRP 900 / SN 5000
+ flat top DIN 4034-1**

www.predl.eu

PREDL®
Schutzvermerk nach DIN34 beachten

new manhole in old manhole

b
A4

Pfad:

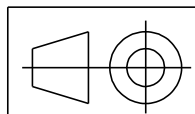
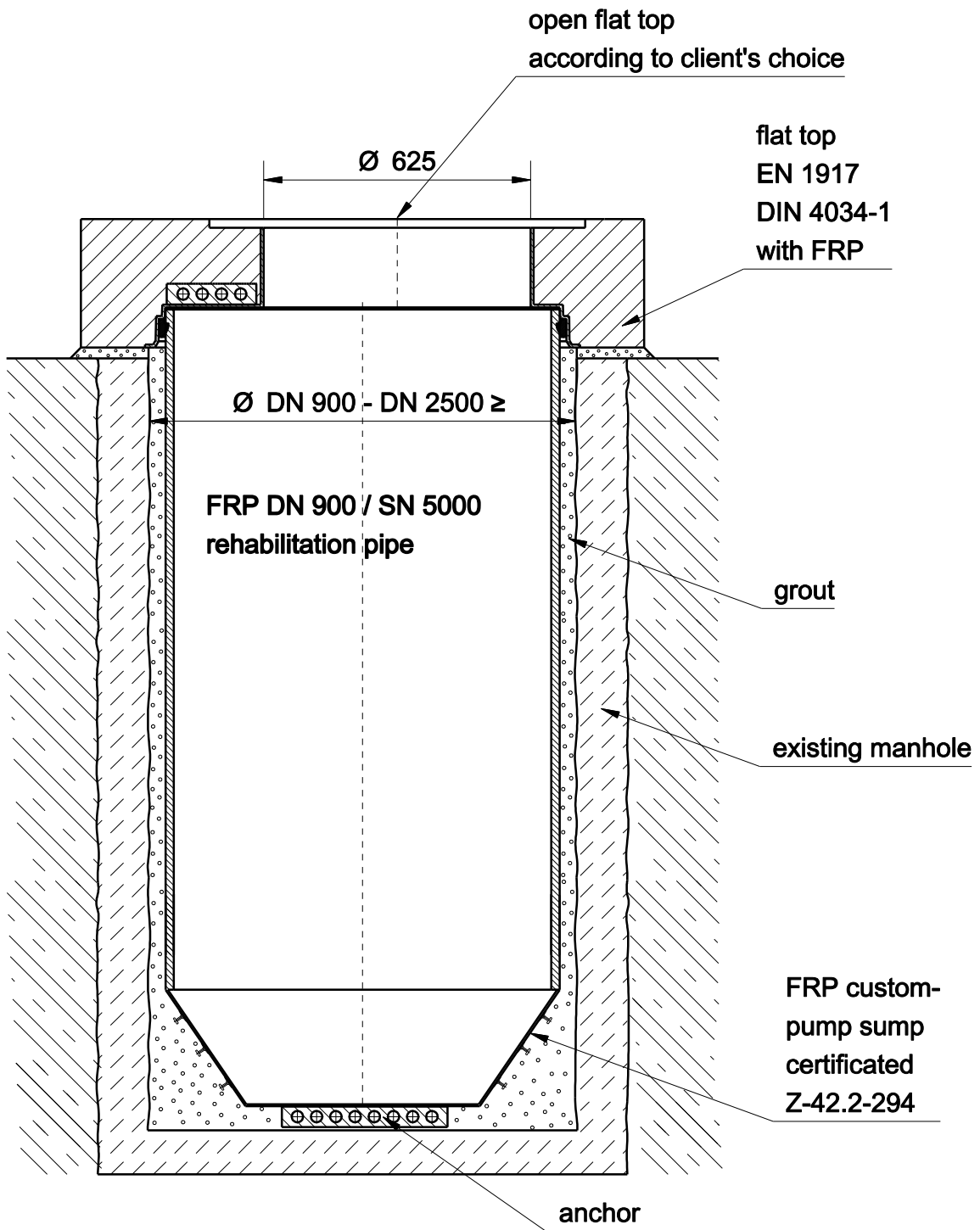

	Datum	Name
Gezeichnet	05.04.2022	E. Nadulski
geändert		
geändert		

www.predl.eu



Pfad:

Menge: Maßstab:

Material: Gewicht: Dichte:

FRP custom - pump sump

new manhole in old manhole

b
A4

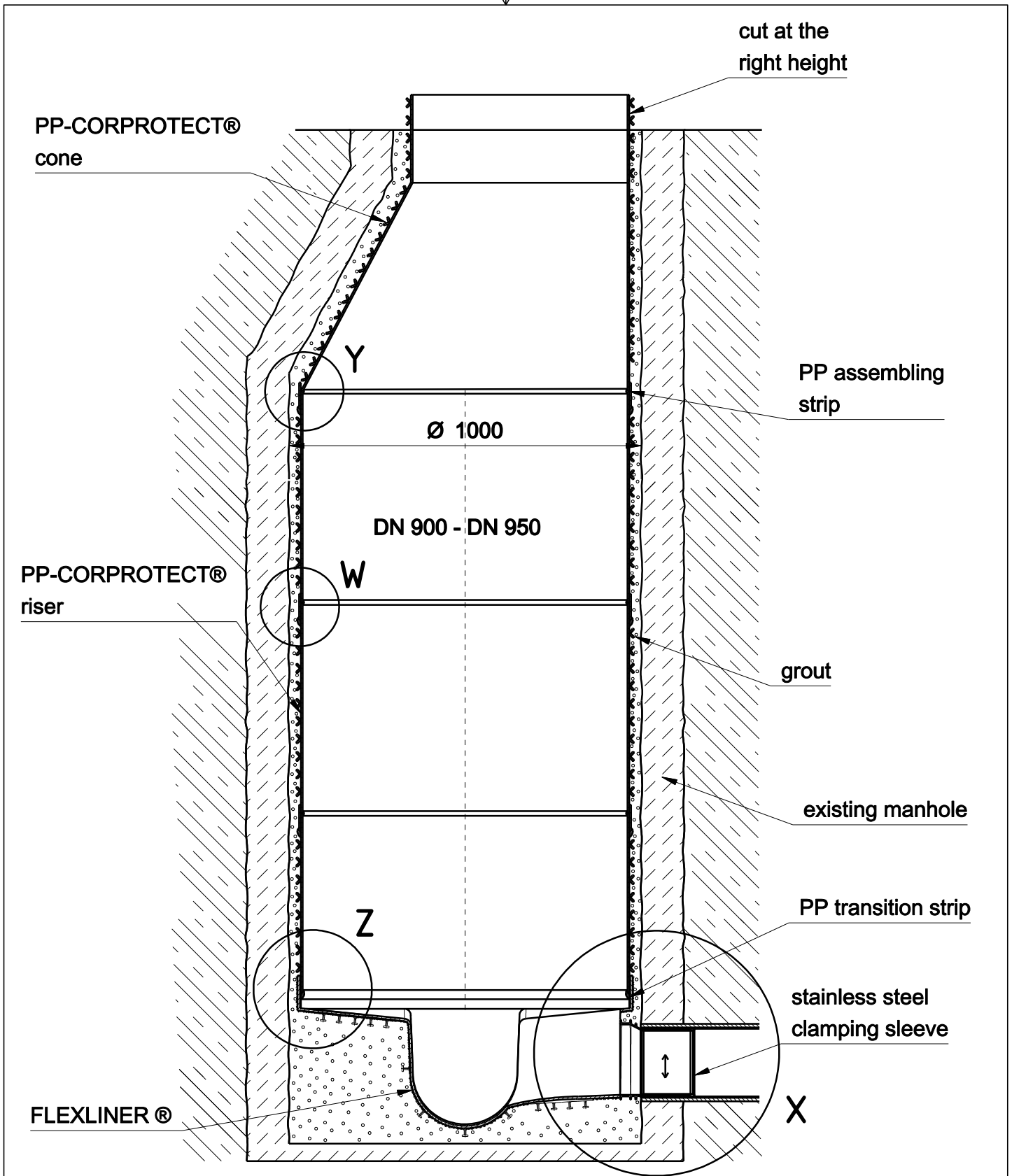

		Menge:	Maßstab:
		Material:	Gewicht: Dichte:
Datum	Name	CORPROTECT® + FLEXLINER®	
Gezeichnet 05.04.2022	E.Nadulski		
geändert			
geändert		www.predl.eu	
		rehabilitation manhole	
Schutzvermerk nach DIN34 beachten		d	
Pfad:		A4	



Connection to the cone with PP assembling strip

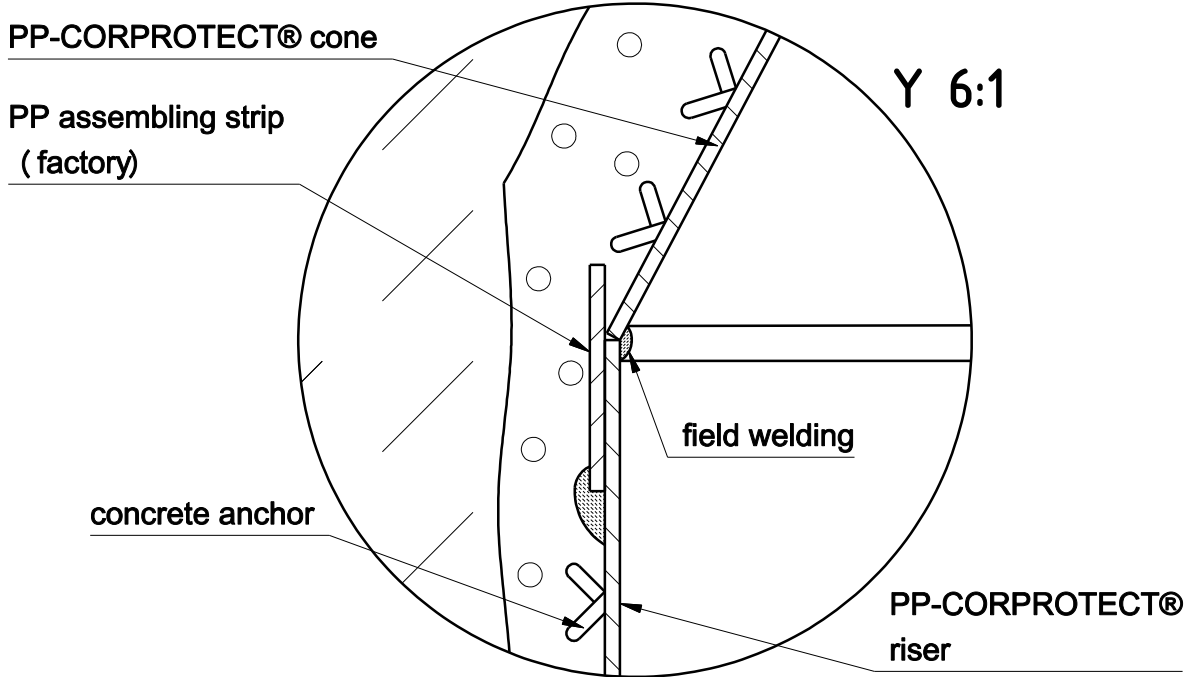

CORPROTECT® connection with transition strip + FLEXLINER®

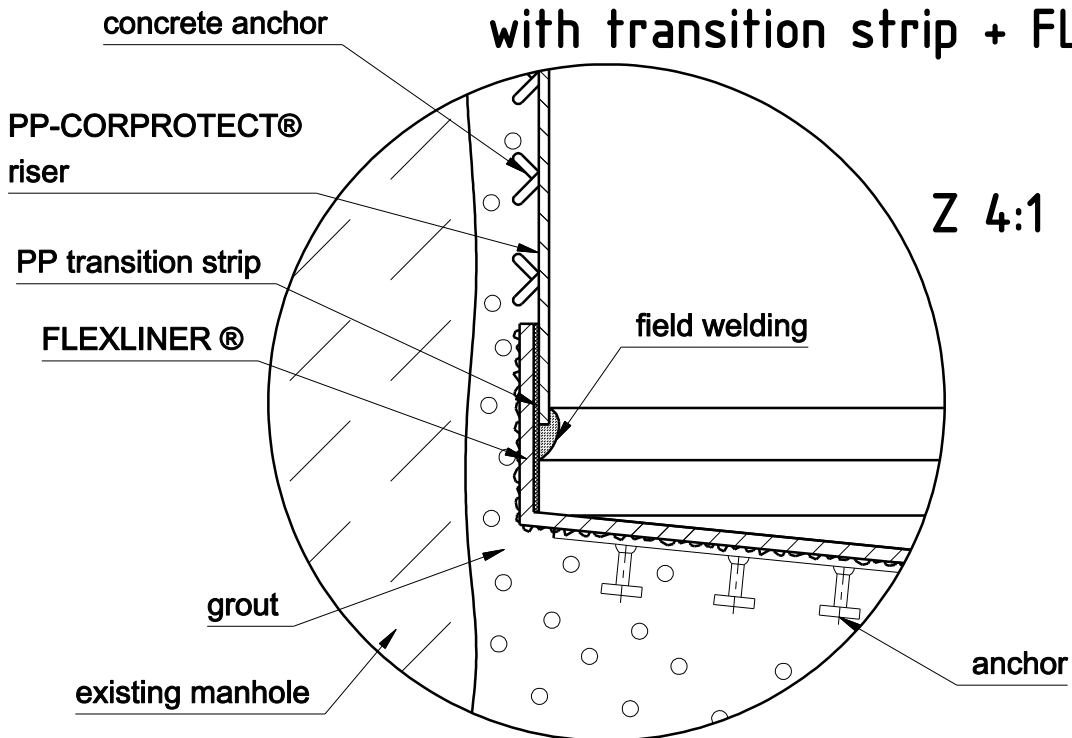

		Menge:	Maßstab:	
		Material:	Gewicht:	Dichte:
Datum	Name	CORPROTECT® + FLEXLINER® connection		
Gezeichnet	05.04.2022 E.Nadulski			
geändert				
www.predl.eu		rehabilitation manhole		d
				A4
Schutzvermerk nach DIN34 beachten Pfad:				

CORPROTECT® connection with transition strip and pipe connect

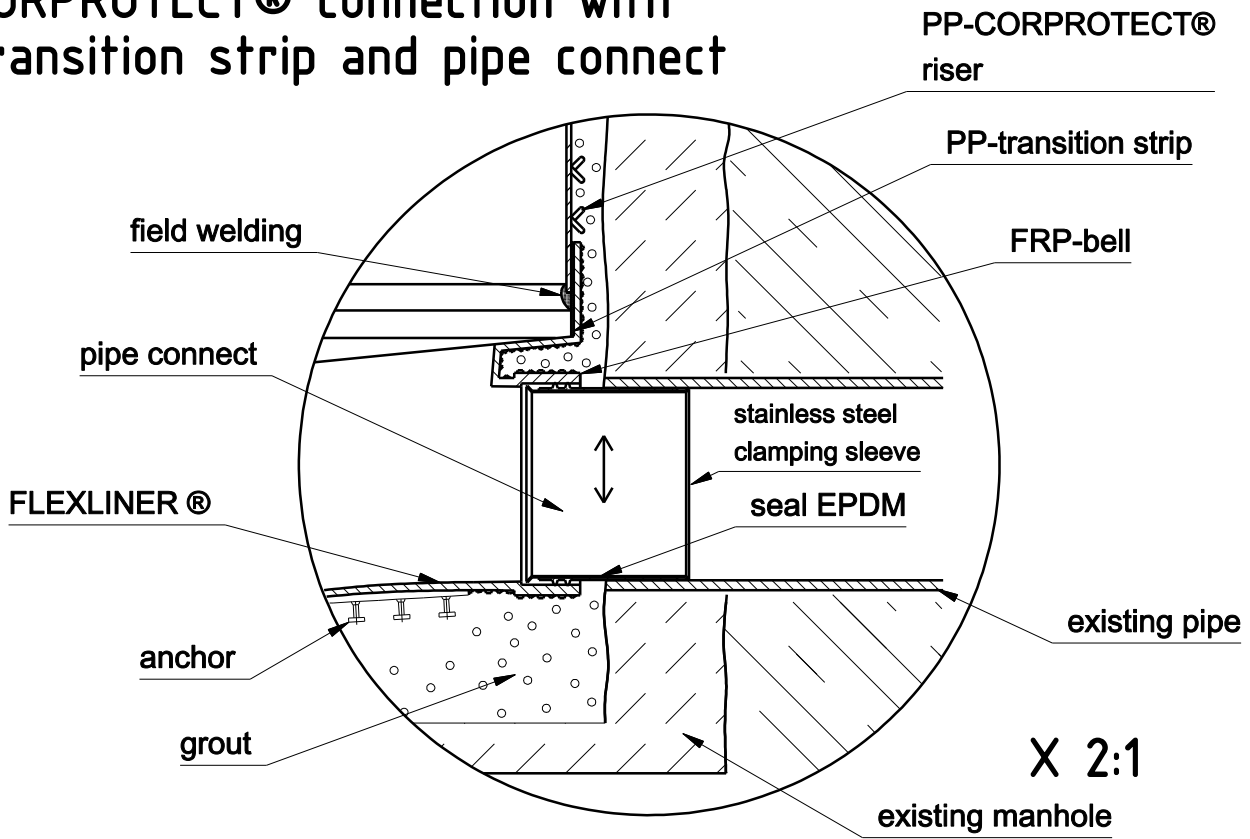

CORPROTECT® connection with PP assembling strip

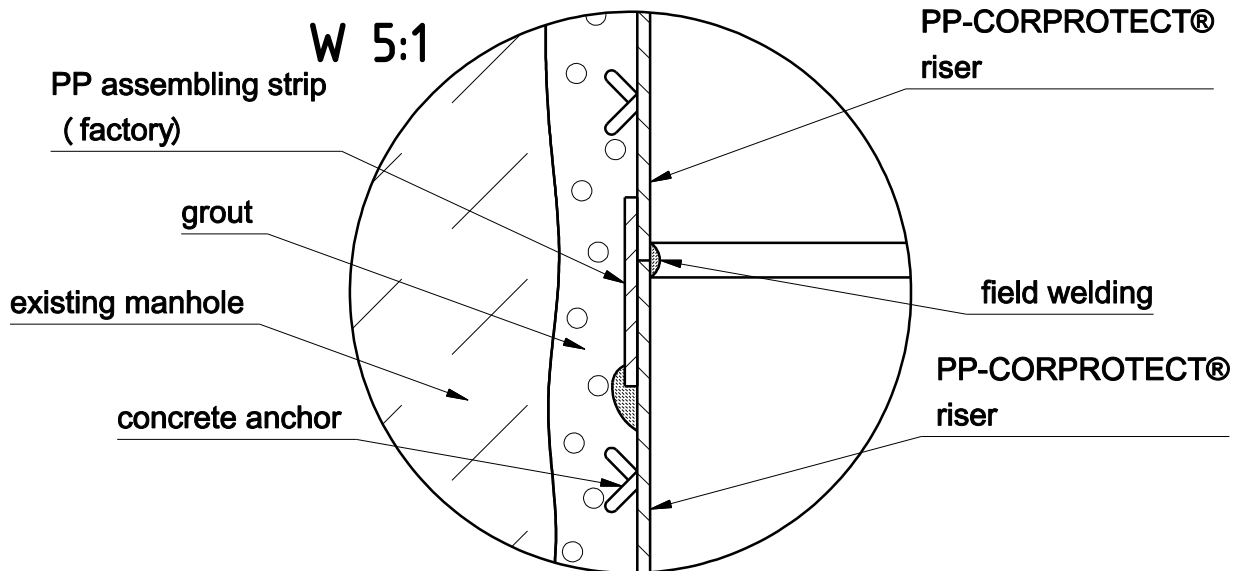

	Menge:		Maßstab:													
	Material:		Gewicht: Dichte:													
<table border="1"> <thead> <tr> <th></th> <th>Datum</th> <th>Name</th> </tr> </thead> <tbody> <tr> <td>Gezeichnet</td> <td>05.04.2022</td> <td>E.Nadulski</td> </tr> <tr> <td>geändert</td> <td></td> <td></td> </tr> <tr> <td>geändert</td> <td></td> <td></td> </tr> </tbody> </table>		Datum	Name	Gezeichnet	05.04.2022	E.Nadulski	geändert			geändert			CORPROTECT® + FLEXLINER® + pipe connect			d A4
	Datum	Name														
Gezeichnet	05.04.2022	E.Nadulski														
geändert																
geändert																
www.predl.eu 																
rehabilitation manhole																
<small>Schutzvermerk nach DIN34 beachten</small> Pfad:																

cone
FRP liner
sheet

cut at the
right height

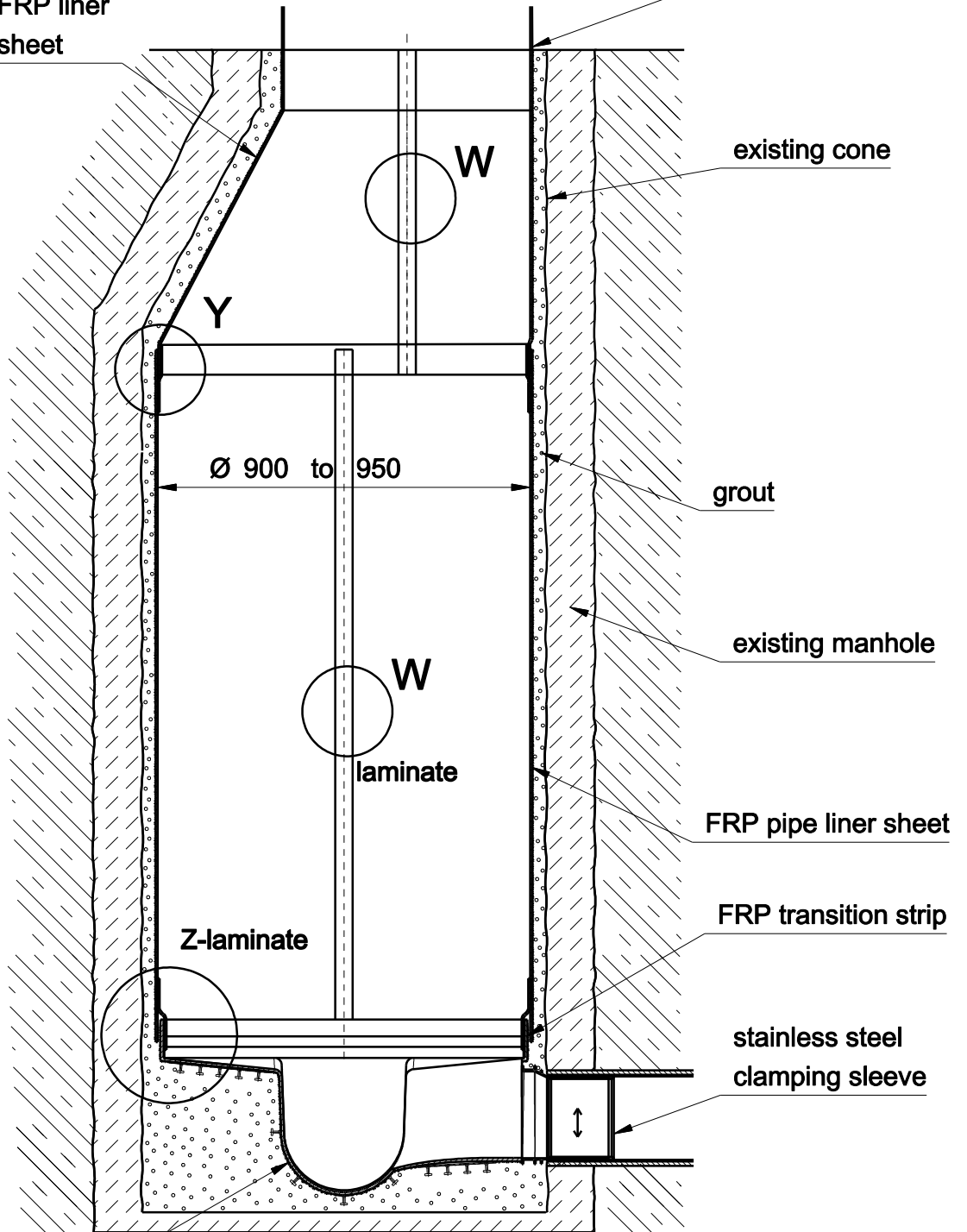

FLEXLINER®

		Menge:		Maßstab:									
		Material:		Gewicht:		Dichte:							
<table border="1"> <tr> <th>Datum</th> <th>Name</th> </tr> <tr> <td>05.04.2022</td> <td>E. Nadulski</td> </tr> <tr> <td>geändert</td> <td></td> </tr> <tr> <td>geändert</td> <td></td> </tr> </table>		Datum	Name	05.04.2022	E. Nadulski	geändert		geändert		<p>FRP liner sheet + FLEXLINER®</p>			
Datum	Name												
05.04.2022	E. Nadulski												
geändert													
geändert													
<p>www.predl.eu</p> <p>PREDL® Schutzvermerk nach DIN34 beachten</p>		<p>rehabilitation manhole</p>		<p>e A4</p>									
<p>Pfad:</p>													

component connections

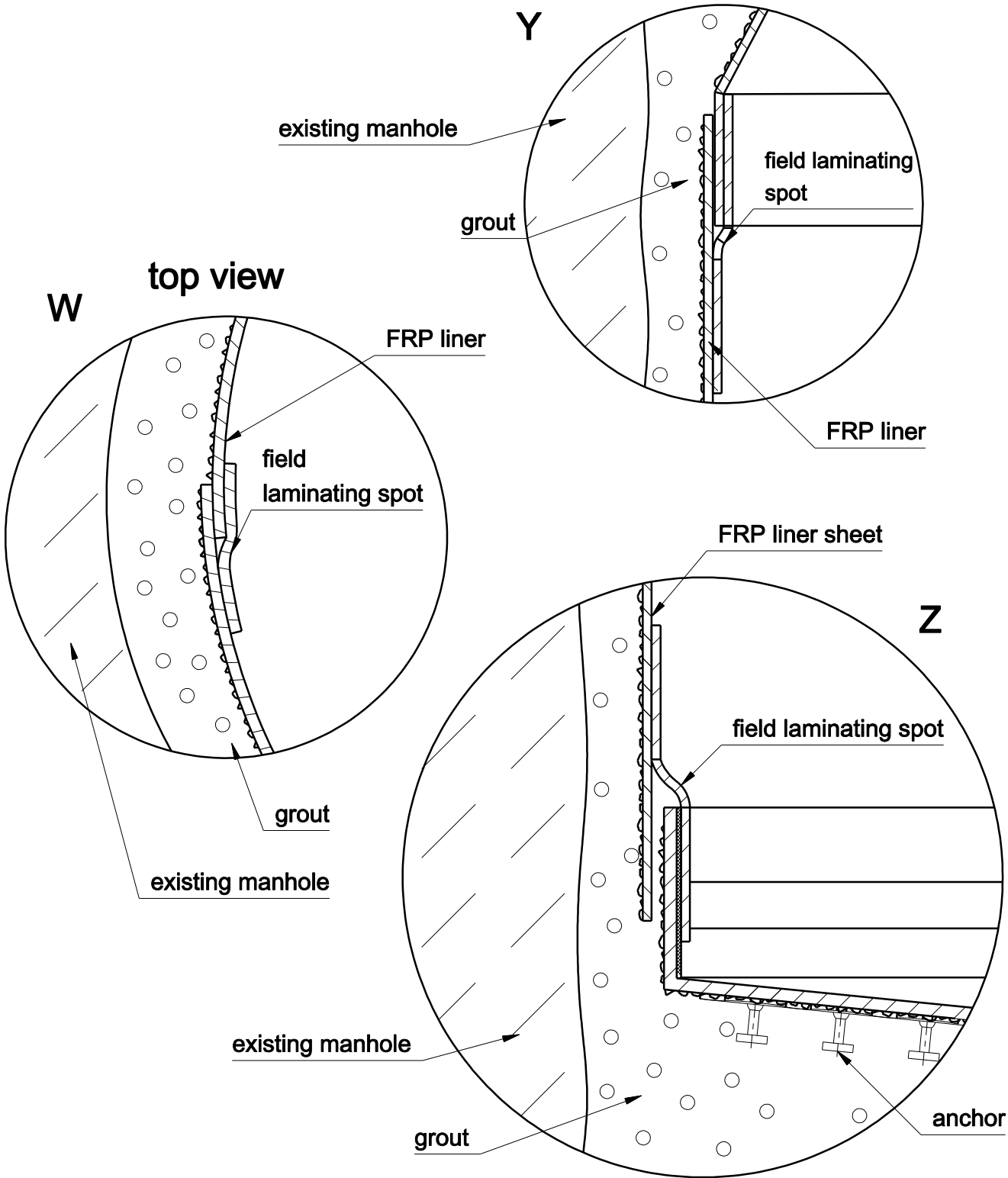

		Menge:		Maßstab:	
		Material:	Gewicht:	Dichte:	
Datum	Name	FRP liner with laminating spot rehabilitation manhole			
Gezeichnet 05.04.2022	E. Nadulski				
geändert					
www.predl.eu					
PREDL [®] <small>Schutzvermerk nach DIN34 beachten</small>					
Pfad:				e A4	

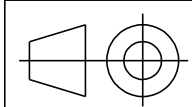
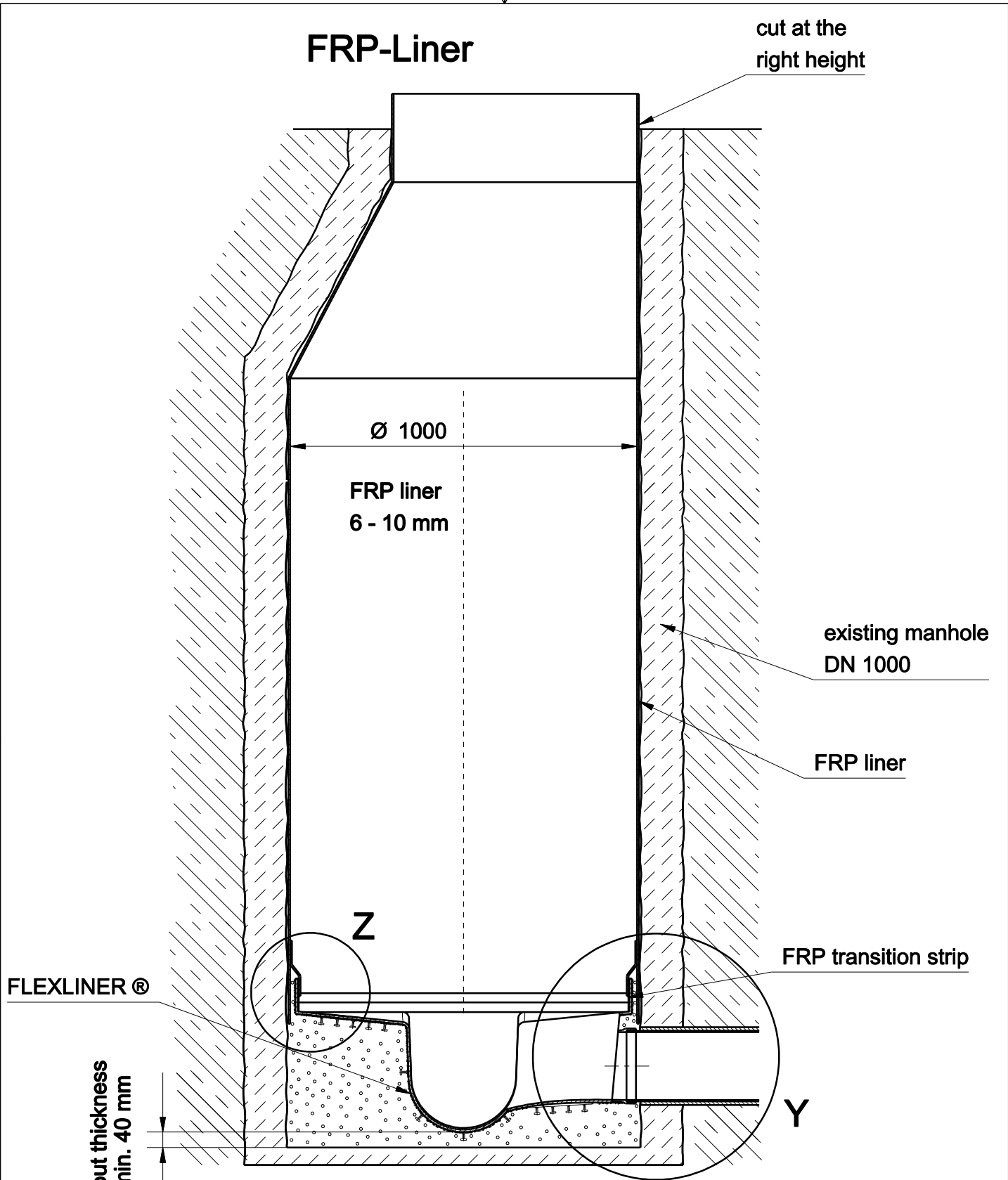

Menge: Maßstab:

Material: Gewicht: Dichte:

	Datum	Name
Gezeichnet	05.04.2022	E. Nadulski
geändert		
geändert		

FRP-Liner + FLEXLINER ®



rehabilitation manhole

f
A4

Pfad:

Connection of the FRP liner with transition strip and pipe connect

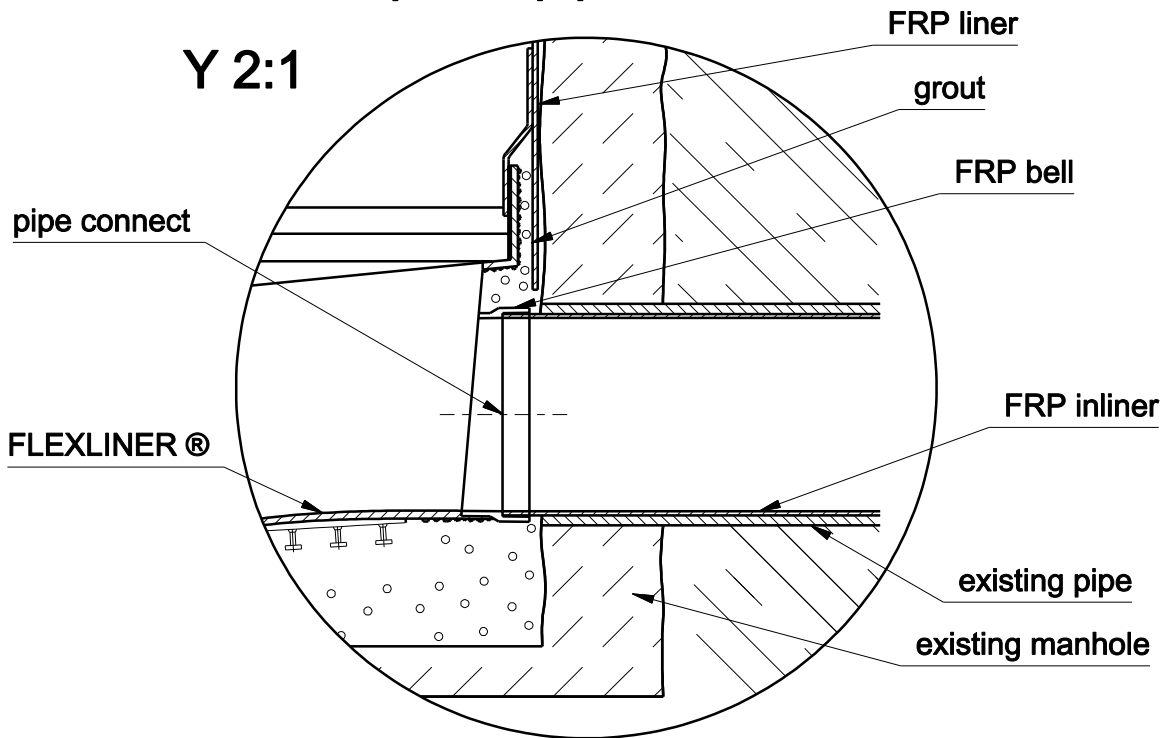

Connection of the FRP liner with transition strip

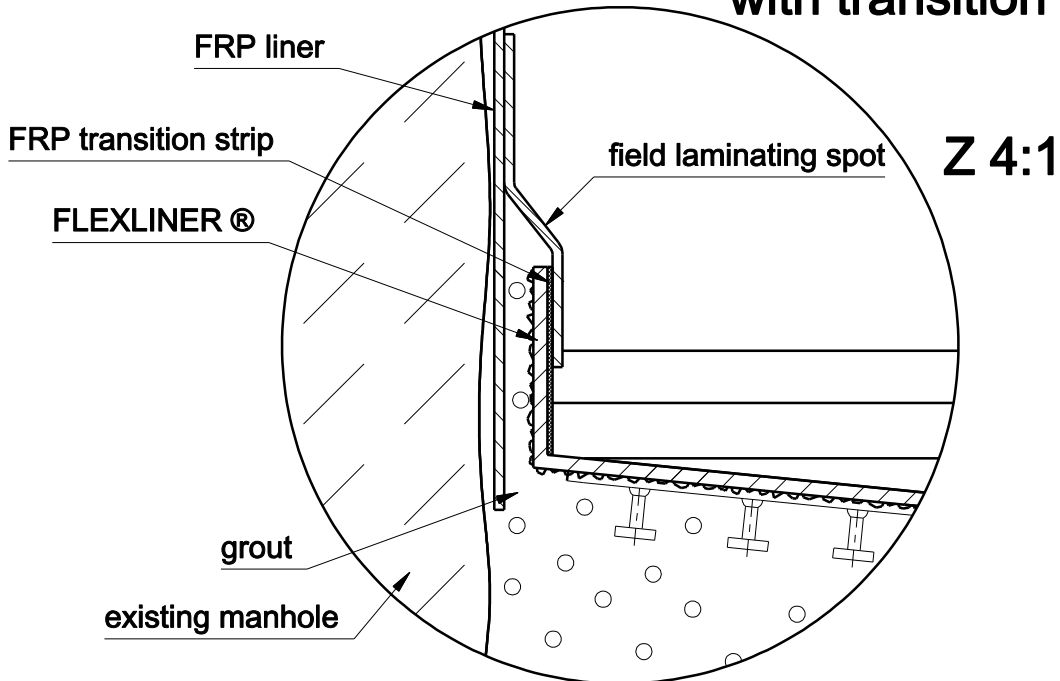

		Menge:	Maßstab:
		Material:	Gewicht: Dichte:
	Datum	Name	FRP-Liner + FLEXLINER® + pipe connect
Gezeichnet	05.04.2022	E. Nadulski	
geändert			
www.predl.eu			
			rehabilitation manhole
Schutzvermerk nach DIN34 beachten			
Pfad:			f A4

rehabilitation manhole with FLEXLINER® und FRP-pipe bell

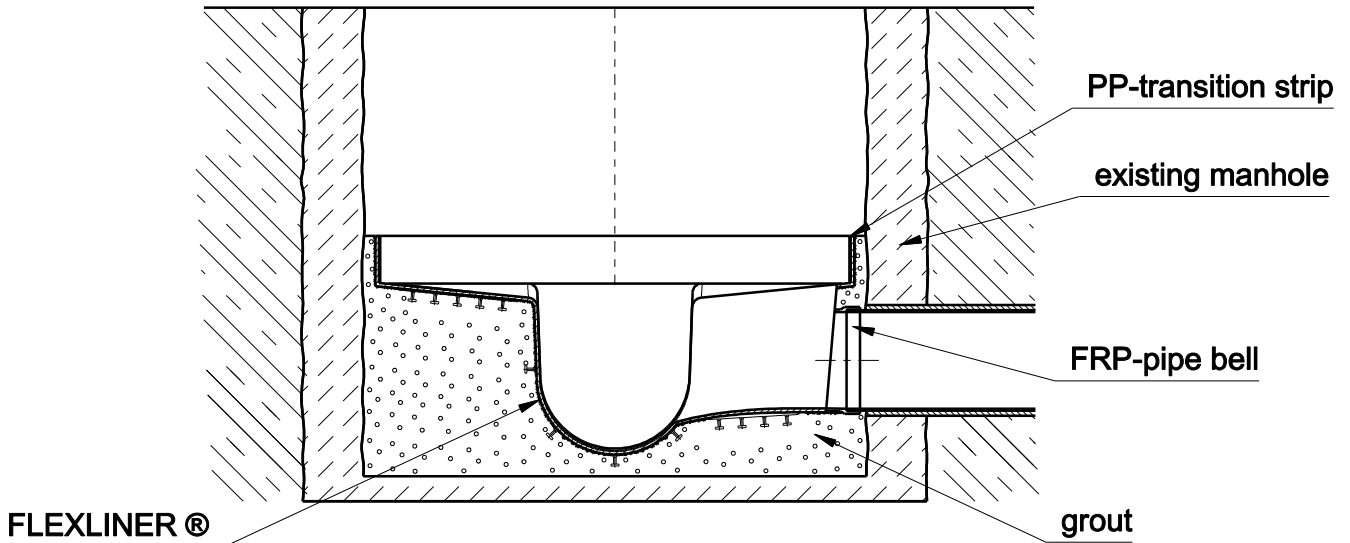

rehabilitation manhole with FLEXLINER® and FRP Bell with stainless steel clamping sleeve

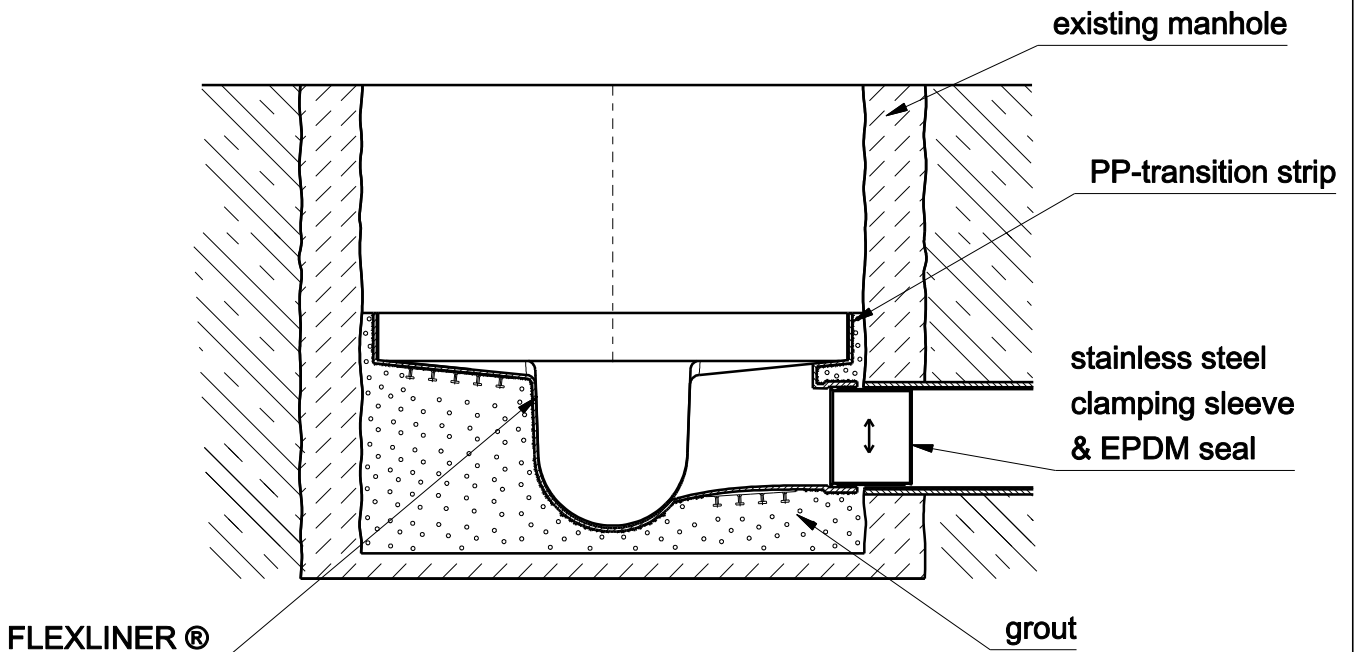

	Menge:		Maßstab:		
	Material:		Gewicht:		Dichte:
	Datum	Name		FLEXLINER® ground rehabilitation rehabilitation manhole	9 A4
Gezeichnet	11.04.2022	E.Nadulski			
geändert					
geändert					
www.predl.eu					
<small>Schutzvermerk nach DIN34 beachten</small>					
Pfad:					

CORPROTECT® connection with transition strip and pipe connect with stainless steel short sleeve

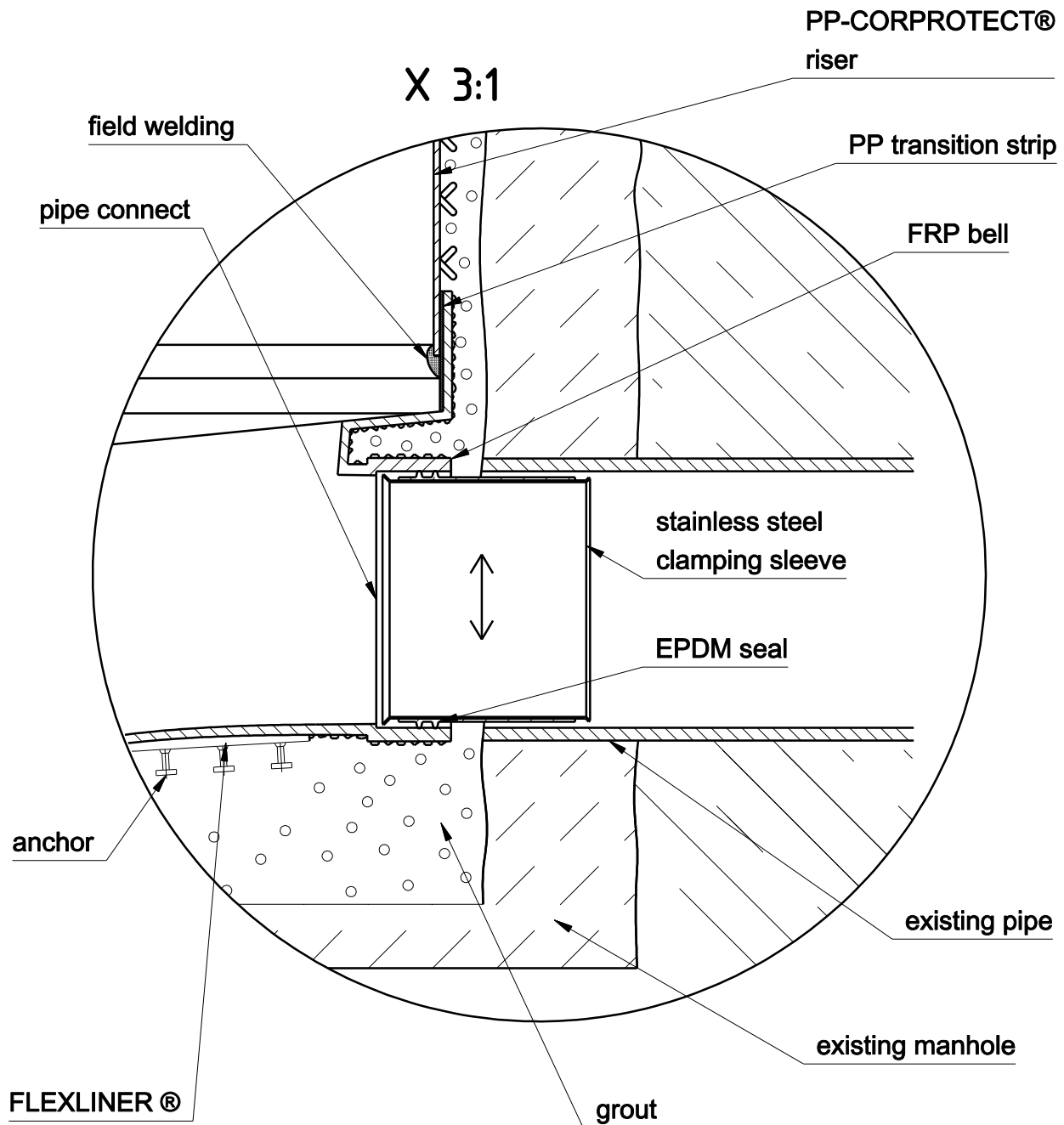

		Menge:	Maßstab:
		Material:	Gewicht: Dichte:
Datum	Name	stainless steel clamping sleeve CORPROTECT® + FLEXLINER®	
Gezeichnet	04.04.2022 E.Nadulski		
geändert			
www.predl.eu		rehabilitation manhole	h
			A4
Schutzvermerk nach DIN34 beachten Pfad:			

CORPROTECT® connection with transition strip and pipe connect with Flex-Connector

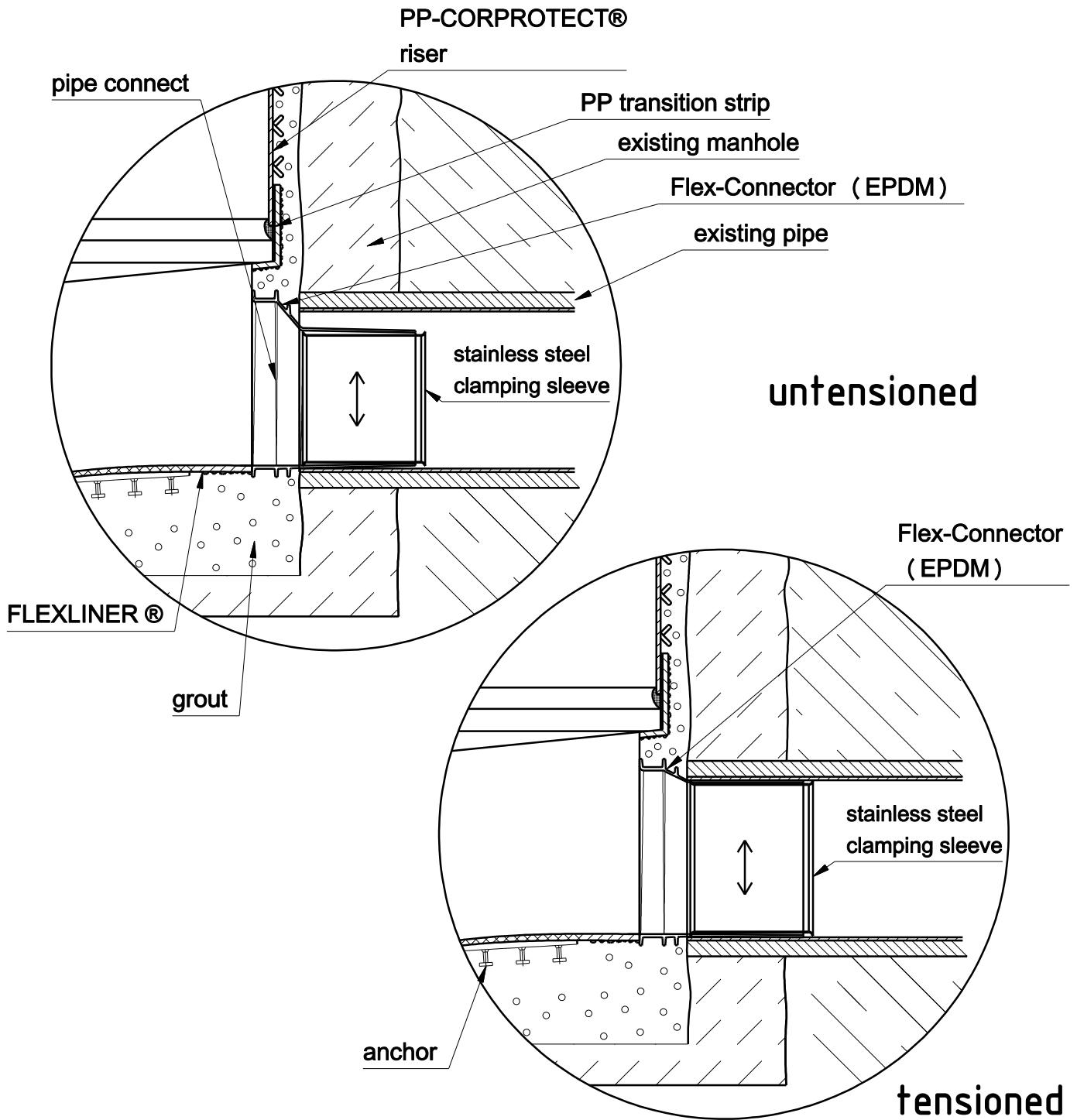

	Menge:		Maßstab:													
	Material:		Gewicht:	Dichte:												
<table border="1"> <tr> <td></td> <td>Datum</td> <td>Name</td> </tr> <tr> <td>Gezeichnet</td> <td>04.04.2022</td> <td>E.Nadulski</td> </tr> <tr> <td>geändert</td> <td></td> <td></td> </tr> <tr> <td>geändert</td> <td></td> <td></td> </tr> </table>		Datum	Name	Gezeichnet	04.04.2022	E.Nadulski	geändert			geändert			Flex-Connector CORPROTECT® + FLEXLINER®			
	Datum	Name														
Gezeichnet	04.04.2022	E.Nadulski														
geändert																
geändert																
www.predl.eu 			rehabilitation manhole													
Pfad:			i A4													

CORPROTECT® connection with transition strip and pipe connect with FRP-bell

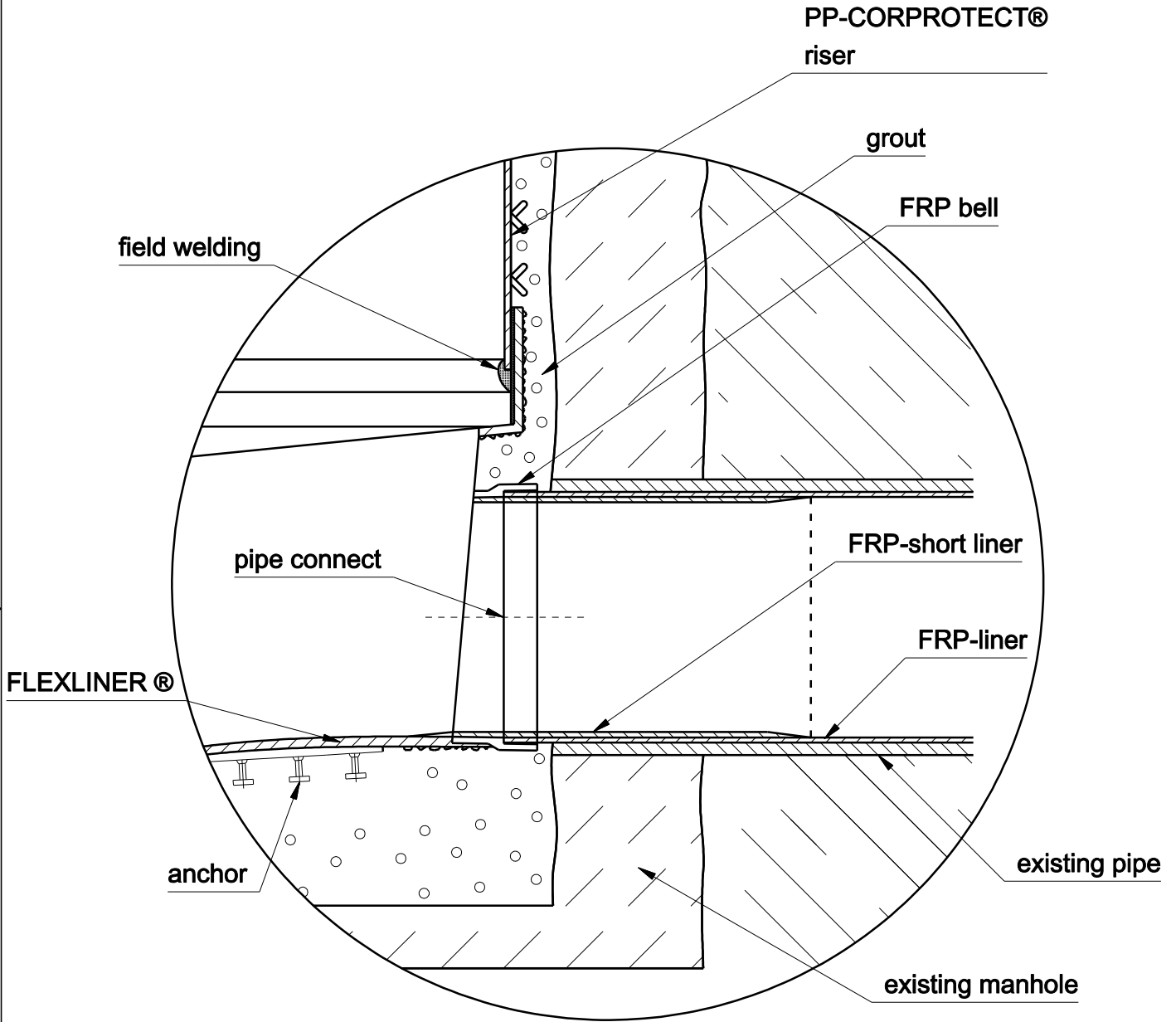

			Menge:	Maßstab:
			Material:	Gewicht: Dichte:
	Datum	Name	FRP-bell	
Gezeichnet	04.04.2022	E.Nadulski	CORPROTECT® + FLEXLINER®	
geändert				
geändert				
www.predl.eu				
			rehabilitation manhole	
Schutzvermerk nach DIN34 beachten			j	
Pfad:			A4	